

VersaFlow Coriolis 100 Mass Flow Sensor Technical Datasheet

34-VF-03-09
29TH May, 2009

Specification

The universal solution for the process industry

VERSAFLOW is the only sensor for mass flow in its class with secondary pressure containment as standard. VERSAFLOW reliably measures mass flow of liquids and gases, concentration and density of liquids.

Highlights

- Innovative twin measuring tube
- Easily drained and easy to clean
- Insensitive of installation and external factors
- Long working life
- Optimized flow divider for minimum pressure loss
- High accuracy with best price-performance ratio
- Modular electronics concept: electronics and sensor easy to replace
- Data redundancy: accurate plug & play replacement of electronics

Industries

- Wastewater
- Chemical
- Food & Beverage
- Paper & Pulp
- Petrochemistry
- Pharmaceutical
- Water



Figure 1 – VersaFlow Mass Flow Sensor

Applications

- Suitable for all standard applications up to 130°C / 266°F
- With hygienic type process connections for food and pharmaceutical applications

Mass flowmeter product family

All meters consist of a sensor and a converter, which may be mounted integral to the sensor, or remotely, either with a field mount kit, a wall mount housing or a 19" rack mount module.

A sensor mount converter (TWC 010) with a Modbus® output only is also possible for OEM manufacturers or where the user does not require a converter with analogue outputs.

Converter: Common hardware for all converters makes spares holding simpler



1. TWC 9000 C: Compact or integrally mounted on sensor
2. TWC 9000 F: Field mount up to 300 m / 1000 ft from sensor
3. TWC 9000 W: Wall mount for non-hazardous areas
4. TWC 9000 R: 19" Rack mount module for control room installation
5. TWC 010: Sensor electronics with Modbus output

Sensor: Sensors for any applications



1. VersaFlow Coriolis 100: The general purpose solution for the process industry
2. VersaFlow Coriolis 1000: The optimum solution for chemical, food & beverage and pharmaceutical industry
3. VersaFlow Coriolis 200 (pending): Large diameter meter suitable for custody transfer measurement

Technical Data

Operating data

Size	S15	S25	S40	S50
------	-----	-----	-----	-----

Flow rate

Maximum flow rate [kg/h]	6500	27000	80000	170000
Maximum flow rate [lbs/min]	240	990	2935	6235

Accuracy

Accuracy, liquid	±0.15% of actual measured flow rate
Accuracy, gas	±0.50% of actual measured flow rate
Repeatability	Better than 0.05% plus zero stability (includes the combined effects of repeatability, linearity and hysteresis)
Zero stability	±0.01% of nominal flow rate with respective sensor size

Reference conditions

Product	Water
Temperature	20°C/68°F
Operating pressure	1 bar _{rel.} / 14.5 psig

Density

Measuring range	400...2500 kg/m ³ / 25...155 lbs/ft ³
Accuracy	±2 kg/m ³ / ±0.13 lbs/ft ³ (S15: ±5 kg/m ³ / ±0.33 lbs/ft ³)
Accuracy (on-site calibration)	±0.5 kg/m ³ / ±0.033 lbs/ft ³

Temperature

Measuring range	-40...+130°C / -40...+266°F
Accuracy	±1°C / ±1.8°F

Materials

Measuring tube	Stainless steel UNS S31803 (1.4462) dual certified
Spigot	Stainless steel 316 / 316L (CF3M / 1.4409) dual certified
Flanges	Stainless steel 316 / 316L (1.4401 / 1.4404) dual certified
Outer cylinder (secondary pressure containment)	Stainless steel 304 / 304L (1.4301 / 1.4307) dual certified (Optional Stainless Steel 316 / 316L (1.4401 / 1.4404) dual certified)
Junction Box – remote version	Die cast Aluminum (polyurethane coating) Optional Stainless Steel 316L (1.4401)
Heating jacket version	
Heating jacket	Stainless Steel 316L (1.4404) (The outer cylinder is in contact with the heating medium)

Nominal pressure at 20°C or 68°F

Measuring Tube	-1...100 bar g/ -14.5 ...1450 psig
Outer Cylinder	
Non PED/CRN Approved	Typical burst pressure > 100 barg. / 1450 psig
PED/CRN Approved secondary containment	-1...63 barg. / -14.5...910 psig
PED approved secondary containment	-1...100 barg. / -14.5...1450 psig

Approvals and Certifications

<u>Mechanical:</u>	
Electromagnetic compatibility (EMC) acc. to CE	Namur NE 21/5.95 89/336/EEC (EMC) 72/73/EEC (Low Voltage Directive)
Protection category (acc. to EN 60529)	IP 67; NEMA 4X
European Pressure Equipment Directive	PED 97-23 EC (acc. to AD 2000 Regelwerk)
<u>Factory Mutual / CSA</u>	Class I, Div 1 groups A, B, C, D Class II, Div 1 groups E, F, G Class III, Div 1 hazardous areas Class I, Div 2 groups A, B, C, D Class II, Div 2 groups F, G Class III, Div 2 hazardous areas
ANSI / CSA (Dual Seal)	12.27.901-2003
Hygienic	3A 28-03
<u>ATEX (acc. 94/9/EC)</u>	
Coriolis 100 with TWM9000C non Ex i Signal outputs without heating jacket / insulation	
Ex d connection compartment	II 2 G Ex d [ib] IIC T4....T1 Optional: II 2 G Ex d [ib] IIC T6....T1 II 2 D Ex tD A21 IP6x T185°C Optional: II 2 D Ex tD A21 IP6x T160°C
Ex e connection compartment	II 2 G Ex de [ib] IIC T4....T1 Optional: II 2 G Ex de [ib] IIC T6....T1 II 2 D Ex tD A21 IP6x T185°C Optional: II 2 D Ex tD A21 IP6x T160°C
Coriolis 100 with TWM9000C non Ex i signal outputs with heating jacket / insulation	
Ex d connection compartment	II 2 G Ex d [ib] IIC T4....T1 Optional: II 2 G Ex d [ib] IIC T6....T1 II 2 D Ex tD A21 IP6x T195°C Optional: II 2 D Ex tD A21 IP6x T165°C
Ex e connection compartment	II 2 G Ex de [ib] IIC T4....T1 Optional: II 2 G Ex de [ib] IIC T6....T1 II 2 D Ex tD A21 IP6x T195°C Optional: II 2 D Ex tD A21 IP6x T165°C
Coriolis 100 with TWM9000C Ex i signal outputs without heating jacket / insulation	
Ex d connection compartment	II 2(1) G Ex d [ia/ib] IIC T4....T1 Optional: II 2(1) G Ex d [ia/ib] IIC T6....T1 II 2(1) D Ex tD [iaD] A21 IP6x T185°C Optional: II 2(1) D Ex tD [iaD] A21 IP6x T160°C
Ex e connection compartment	II 2(1) G Ex de [ia/ib] IIC T4....T1 Optional: II 2(1) G Ex de [ia/ib] IIC T6....T1 II 2(1) D Ex tD [iaD] A21 IP6x T185°C Optional: II 2(1) D Ex tD [iaD] A21 IP6x T160°C

Coriolis 100 with TWM9000C Ex i signal outputs with heating jacket / insulation	
Ex d connection compartment	<p>II 2(1) G Ex d [ia/ib] IIC T4...T1 Optional: II 2(1) G Ex d [ia/ib] IIC T6...T1 II 2(1) D Ex tD [iaD] A21 IP6x T195°C Optional: II 2(1) D Ex tD [iaD] A21 IP6x T165°C</p>
Ex e connection compartment	<p>II 2(1) G Ex de [ia/ib] IIC T4...T1 Optional: II 2(1) G Ex de [ia/ib] IIC T6...T1 II 2(1) D Ex tD [iaD] A21 IP6x T195°C Optional: II 2(1) D Ex tD [iaD] A21 IP6x T165°C</p>
Coriolis 100 with TWM9000F or TWC 010, without heating/ insulation	
	<p>II 2 G Ex ib IIC T4...T1 Optional: II 2 G Ex ib IIC T6...T1 II 2 D Ex ibD 21 T175 °C Optional: II 2 D Ex ibD 21 T165 °C</p>
Coriolis 100 with TWM9000F or TWC 010 with heating / insulation	
	<p>II 2 G Ex ib IIC T4...T1 Optional: II 2 G Ex ib IIC T6...T1 II 2 D Ex ibD 21 T175 °C Optional: II 2 D Ex ibD 21 T165 °C</p>
NEPSI (with TWC9000C/F, TWC 010)	Exdeib(ia)II C T1...T6, Exdib(ia)II C T1...T6

Temperature

Process temperature - flanged connections	-40...+130°C / -40...+266°F
Process temperature - hygienic connections	-20...+130°C / -4...+266°F
Ambient temperature - compact version	<p>40...+60°C / -40...+140°F for Aluminum converter (Extended temperature range: +65°C / +149°F for some I/O options. For more information contact manufacturer.) -40...+55°C / -40...+130°F for Stainless Steel converter</p>
Ambient temperature - remote version	-40...+65°C / -40...+149°F

Process effects on the sensor

Temperature	0.001% per 1°C / 0.00055% per 1°F
Pressure	0.00012% of the max flow rate per 1 bar _{rel} / 0.0000083% of the max flow rate per 1 psig

Dimensions and weights

Flanged versions

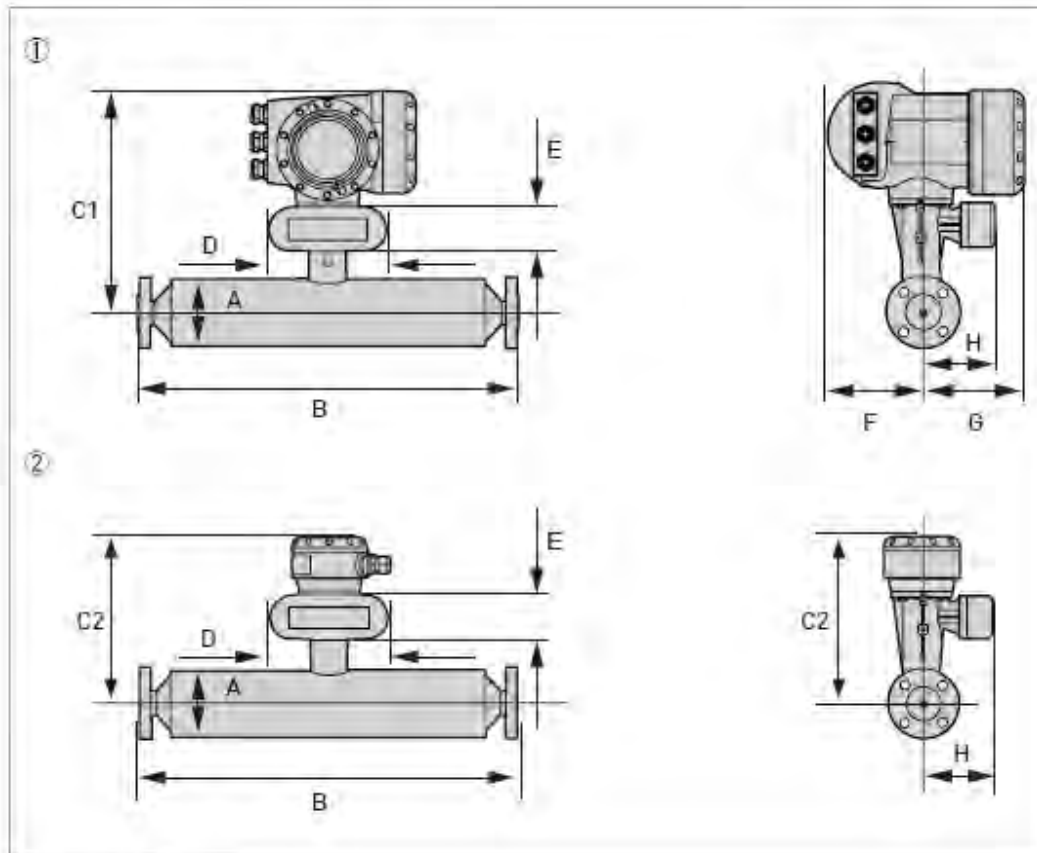

- ① Compact version
- ② Remote version

Meter weights (all flanges)

Weight – kg (lbs)

	S15	S25	S40	S50
Aluminium (compact)	13.5 (30)	16.5 (36.3)	29.5 (65)	57.5 (127)
Stainless Steel (compact)	18.8 (41)	21.8 (48)	34.8 (77)	62.8 (138)
Aluminium (remote)	11.5 (25)	14.5 (32)	25.5 (56)	51.5 (113)
Stainless Steel (remote)	12.4 (27)	15.4 (33.8)	26.4 (58)	52.4 (115)

Measuring tube Stainless Steel

Dimensions – mm (inches)

	S15	S25	S40	S50
A	101.6 (4)	114.3 (4.5)	168.3 (6.6)	219.1 (8.6)
C1 (compact)	311 (12.2)	317 (12.5)	344 (13.5)	370 (14.6)
C2 (remote)	231 (9)	237 (9.3)	264 (10.4)	290 (11.4)
D	160 (6.3)			
E	60 (2.4)			
F	123.5 (2.4)			
G	137 (5.4)			
H	98.5 (3.9)			

Flange connections

Dimension B (mm)

	S15	S25	S40	S50
PN40				
DN15	498			
DN25	503	531		
DN40		541	706	
DN50			712	862
DN80				882

Dimension B (mm)

	S15	S25	S40	S50
PN63				
DN50			740	890
DN80				910

Dimension B (mm)

	S15	S25	S40	S50
PN100				
DN15	513			
DN25	538	567		
DN40		575	740	
DN50			752	902
DN80				922

Dimension B (mm)

	S15	S25	S40	S50
ASME 150				
½"	518			
¾"	528			
1"	534	563		
1½"		575	740	
2"			744	894
3"				906

Dimension B (mm)

	S15	S25	S40	S50
ASME300				
½"	528			
¾"	538			
1"	546	575		
1½"		589	754	
2"			756	906
3"				926

Dimension B (mm)

	S15	S25	S40	S50
ASME 600				
½"	541			
¾"	550			
1"	558	589		
1½"		603	770	
2"			744	926
3"				944

Dimension B (mm)

	S15	S25	S40	S50
JIS 10K				
50A			712	862
80A				882

Dimension B (mm)

	S15	S25	S40	S50
JIS 20K				
15A	498			
25A	503	531		
40A		541	706	
50A			712	862
80A				882

Dimension B (inches)

	S15	S25	S40	S50
PN40				
DN15	19.6			
DN25	19.8	21		
DN40		21.6	27.8	
DN50			28	33.9
DN80				34.7

Dimension B (inches)

	S15	S25	S40	S50
PN63				
DN50			29	35
DN80				35.8

Dimension B (inches)

	S15	S25	S40	S50
PN100				
DN15	20.2			
DN25	21.2	22.3		
DN40		22.6	29	
DN50			29.6	35.5
DN80				36.3

Dimension B (inches)

	S15	S25	S40	S50
ASME 150				
½"	20.4			
¾"	20.8			
1"	21	22.2		
1½"		22.5	29.1	
2"			29.3	35.2
3"				35.7

Dimension B (inches)

	S15	S25	S40	S50
ASME300				
1/2"	20.8			
3/4"	21.2			
1"	21.5	22.6		
1 1/2"		23.2	29.7	
2"			29.8	35.7
3"				36.4

Dimension B (inches)

	S15	S25	S40	S50
ASME 600				
1/2"	21.3			
3/4"	21.6			
1"	22	23.2		
1 1/2"		23.7	30.3	
2"			30.5	36.4
3"				37.2

Dimension B (inches)

	S15	S25	S40	S50
JIS 10K				
50A			28	33.9
80A				34.7

Dimension B (inches)

	S15	S25	S40	S50
JIS 20K				
15A	19.6			
25A	19.8	20.9		
40A		21.3	27.8	
50A			28	33.9
80A				34.7

2.4.2 Hygienic versions

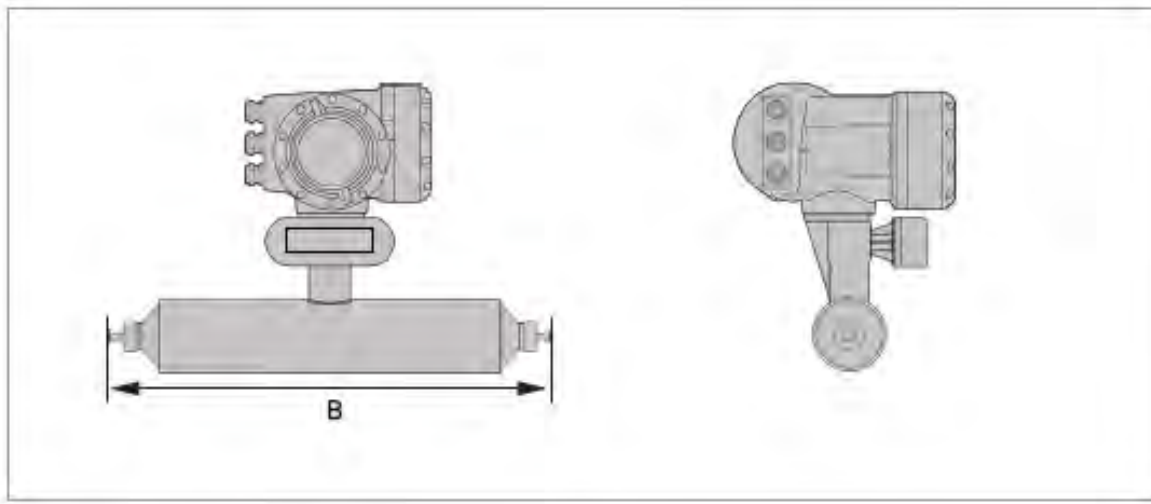

Hygienic connections: all welded versions

Dimension B (mm)

	S15	S25	S40	S50
Tri-clover				
1"	487			
1½"		534		
2"			691	
3"				832

Dimension B (mm)

	S15	S25	S40	S50
Tri-clamp DIN 32676				
DN10				
DN15				
DN25	468			
DN40		515		
DN50			677	
DN80				836

Dimension B (mm)

	S15	S25	S40	S50
Tri-clamp ISO 2852				
1"	473			
1½"		502		
2"			667	
3"				817

Dimension B (mm)

	S15	S25	S40	S50
DIN 11864-2 form A				
DN25	505			
DN40		562		
DN50			724	
DN80				896

Dimension B (inches)

	S15	S25	S40	S50
Tri-clover				
1"	19.2			
1½"		21		
2"			27.2	
3"				32.7

Dimension B (inches)

	S15	S25	S40	S50
Tri-clamp DIN 32676				
DN10				
DN15				
DN25	18.4			
DN40		20.3		
DN50			26.6	
DN80				32.9

Dimension B (inches)

	S15	S25	S40	S50
Tri-clamp ISO 2852				
1"	18.6			
1½"		19.8		
2"			26.3	
3"				32.2

Dimension B (inches)

	S15	S25	S40	S50
DIN 11864-2 form A				
DN25	19.9			
DN40		22.2		
DN50			28.5	
DN80				35.3

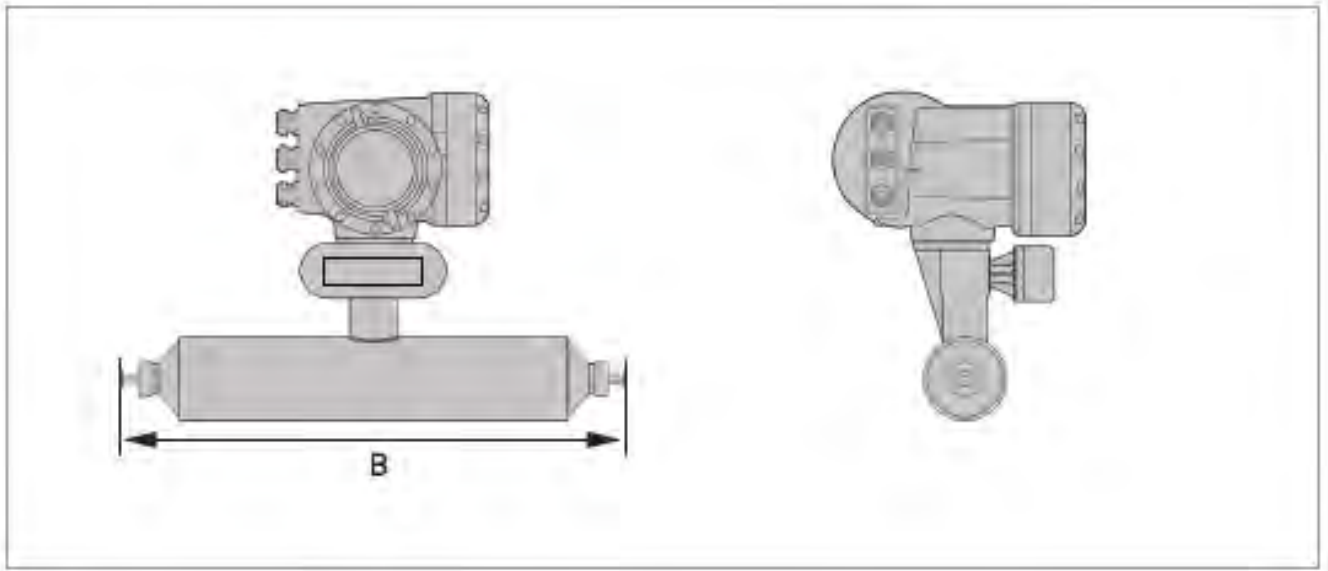

Hygienic connections: adapter versions (male thread)

Dimension B (mm)

	S15	S25	S40	S50
Male thread DIN 11851				
DN25	483			
DN40		538		
DN50			704	
DN80				870

Dimension B (mm)

	S15	S25	S40	S50
Male thread SMS				
1"	474			
1½"		537		
2"			694	
3"				837

Dimension B (mm)

	S15	S25	S40	S50
Male thread IDF/ISS				
1"	487			
1½"		534		
2"			691	
3"				832

Dimension B (mm)

	S15	S25	S40	S50
Male thread RJT				
1"	498			
1½"		545		
2"			702	
3"				843

Dimension B (inches)

	S15	S25	S40	S50
Male thread DIN 11851				
DN25	19			
DN40		21.2		
DN50			27.7	
DN80				34.2

Dimension B (inches)

	S15	S25	S40	S50
Male thread SMS				
1"	18.7			
1½"		21.1		
2"			27.3	
3"				32.9

Dimension B (inches)

	S15	S25	S40	S50
Male thread IDF/ISS				
1"	19.2			
1½"		21		
2"			27.2	
3"				32.7

Dimension B (inches)

	S15	S25	S40	S50
Male thread RJT				
1"	19.6			
1½"		21.4		
2"			27.6	
3"				33.2

Heating jacket version

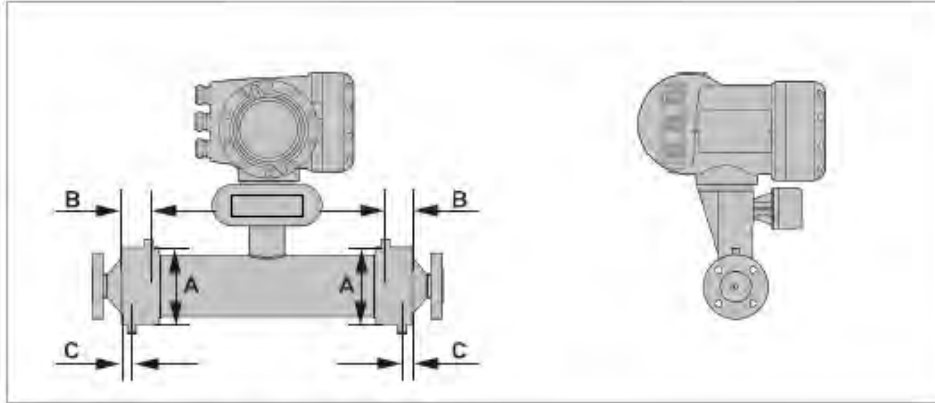

Dimensions – (mm)

	S15	S25	S40	S50
Heating Conn Size	12 mm (ERMETO)			25
A	115 ±1	142 ±1	206 ±1	254 ±1
B	51	55	90	105
C	20			26

Dimensions – (inches)

	S15	S25	S40	S50
Heating Conn Size	½" (NPTF)			1
A	4.5 ±0.04	5.6 ±0.04	8.1 ±0.04	10 ±0.04
B	2.0	2.2	3.5	4.1
C	0.8			1.0

Purge port option

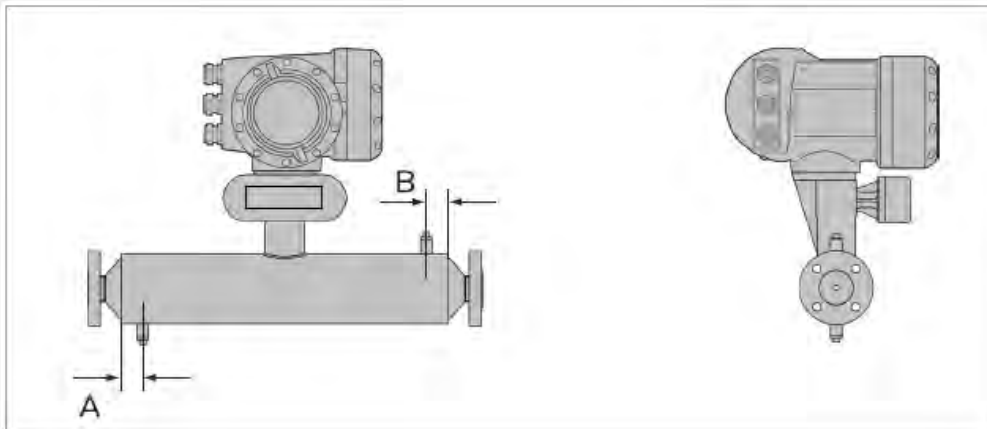

Dimensions – (mm)

	S15	S25	S40	S50
A	30 ±1.0		65 ±1.0	
B	30 ±1.0		65 ±1.0	

Dimensions – (inches)

	S15	S25	S40	S50
A	1.2 ±0.04		2.5 ±0.04	
B	1.2 ±0.04		2.5 ±0.04	

Measuring accuracy

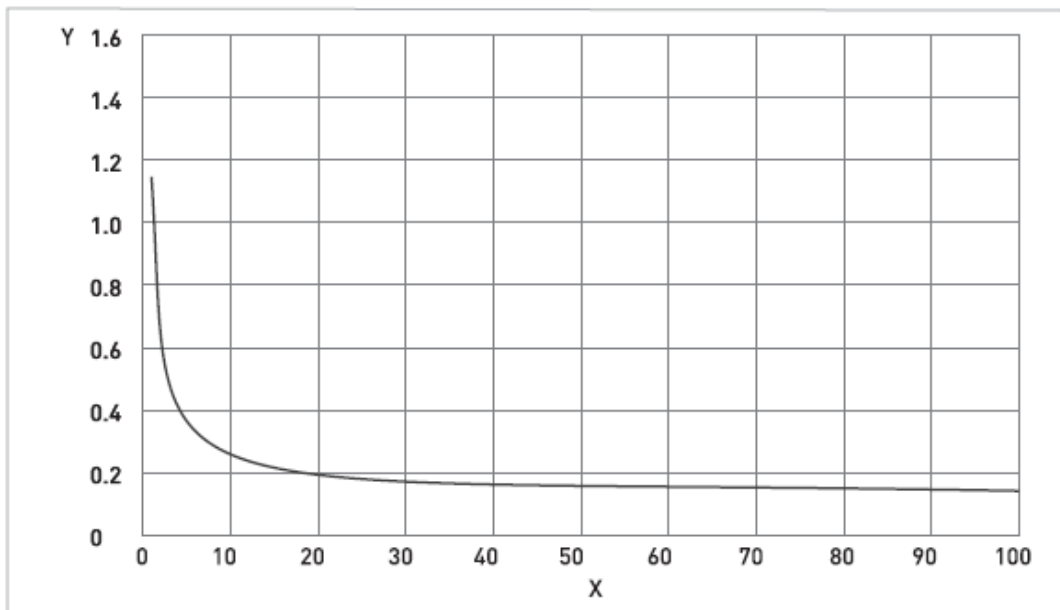

X flow rate [%]
Y measuring error [%]

Measuring error

The measuring error is obtained from the combined effects of accuracy and zero stability.

Reference conditions

Product: Water
Temperature: +20°C / +68°F
Operating pressure: 1 barg / 14.5 psig

Guidelines for maximum operating pressure

Notes

- Ensure that the meter is used within its operating limits
- All hygienic process connections have a maximum operating rating of 10 barg at 130°C / 145 psig at 266°F

Pressure / temperature de-rating, all meter sizes, in metric (flanged connections as per EN 1092-1)

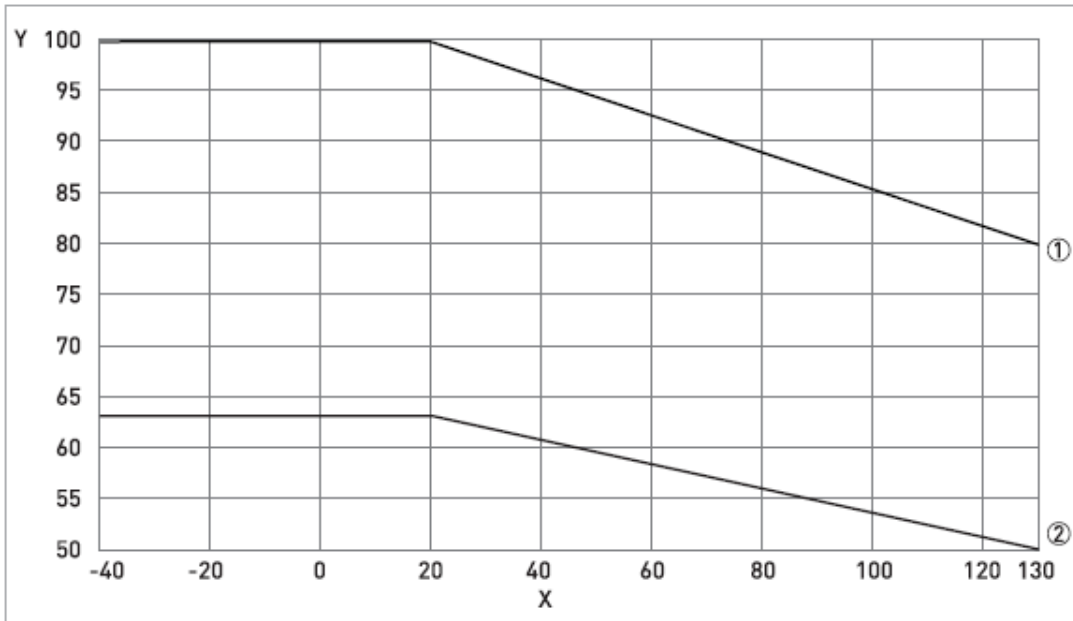

X temperature [°C]
Y pressure [barg]

- 1 Measuring tubes and 100barg 316L secondary containment (PED)
2 63 barg 304L / 316 secondary containment (PED)

Pressure / temperature de-rating, all meter sizes, in imperial (flanged connections as per ASME B16.5)

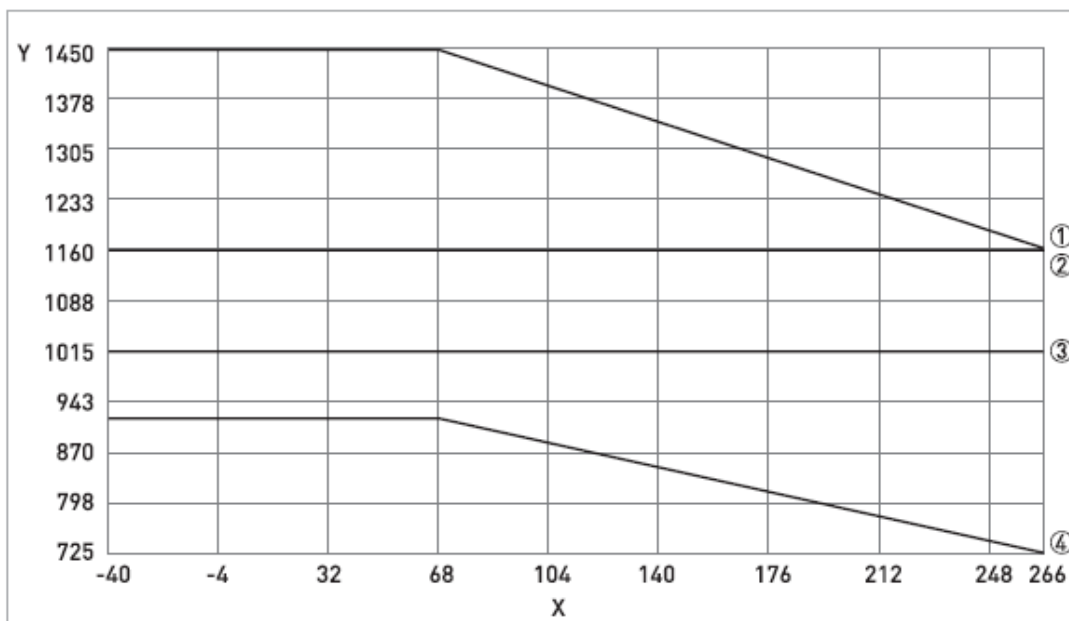

X temperature [°F]
Y pressure [psig]

- 1 Measuring tubes S15 / S25 (CRN)
- 2 Measuring tubes S40 (CRN)
- 3 Measuring tubes S50 (CRN)
- 4 Secondary containment 304L / 316L (CRN)

Flanges

- DIN flange ratings are based on EN 1092-1 2007 table G.4.1 material group 14EO
- ASME flange ratings are based on ASME B16.5 2003 table 2 material group 2.2
- JIS flange ratings are based on JIS 2220: 2001 table 1 division 1 material group 022a

Notes

- The maximum operating pressure will be either the flange rating or the measuring tube rating, **WHICHEVER IS THE LOWER!**
- The manufacturer recommends that the seals are replaced at regular intervals. This will maintain the hygienic integrity of the connection.

Ordering Information

Contact your nearest Honeywell sales office, or

In the U.S.:

Honeywell Process Solutions
Honeywell International Inc
2500 West Union Hills Drive
Phoenix, AZ 85027 1-800-343-0228

In Canada:

The Honeywell Centre
155 Gordon Baker Rd.
North York, Ontario M2H 3N7
1-800-461-0013

In Latin America:

Honeywell Inc.
480 Sawgrass Corporate Parkway,
Suite 200 Sunrise, FL 33325
(954) 845-2600

In Europe and Africa:

Honeywell S. A.
Avenue du Bourget 1
1140 Brussels, Belgium

In Eastern Europe:

Honeywell Praha,
s.r.o. Budejovicka 1
140 21 Prague 4,
Czech Republic

In the Middle East:

Honeywell Middle East Ltd.
Khalifa Street,
Sheikh Faisal Building
Abu Dhabi, U. A. E.

In Asia:

Honeywell Asia Pacific Inc.
Honeywell Building,
17 Changi Business Park Central 1
Singapore 486073
Republic of Singapore

In the Pacific:

Honeywell Pty Ltd.
5 Thomas Holt Drive
North Ryde NSW Australia 2113
(61 2) 9353 7000

In Japan:

Honeywell K.K.
14-6 Shibaura 1-chrome
Minato-ku, Tokyo, Japan 105-0023

Or, visit Honeywell on the World Wide Web at: <http://www.honeywell.com/ps>
Specifications are subject to change without notice.